

Application Data

Alternator Specifications		Engine Mechanical Specifications	
Manufacturer	Newage Stamford	Manufacturer	Perkins
Type	4-pole, rotating field	Engine model	1306C E87TAG3
Exciter type	Brushless, self excited. (PMG option)	Engine type	4-cycle, Turbocharged After-cooled
Leads: quantity, type	12, reconnectable	Cylinder arrangement	6 in line
Voltage regulator	Solid state, volts/Hz and excitation overload protection	EPA Certification :	TIER 2
Insulation:		Displacement, L (cu. in.)	8.7 (531)
Material.....	Class H	Bore and stroke, mm (in.)	116.6 x 135.9 (4.59 x 5.35)
Temperature rise.....	150° C , standby	Compression ratio	16.9 : 1
Bearing: quantity, type	Single bearing sealed	Piston speed, m/min. (ft./min.)	492 (1,614)
Coupling	Flexible disc	Main bearings: quantity, type	7, replaceable insert
Amortisseur Windings	Full	Rated rpm	1,800
Voltage regulation, no-load to full load	± 1.0% (with PMG) ± 1.5% (with Self Excited)	Max. power at rated rpm, kWm (BHP)	227 (305)
Unbalanced load capability	100% of rated standby current	BMEP, gross, psi (Bar)	252.0 (17.4)
Load acceptance	Per ISO - 8528	Overall thermal efficiency	40.5%
Peak motor starting kVA:	(30% dip)	Exhaust Gas Flow, m ³ /min (cfm)	48.1 (1,697)
480 V	self-excited series 4 - 735 kVA	Exhaust gas temperature °C (°F)	461 (862)
480 V	PMG series. 3 - 920 kVA		
Engine Electrical Specifications		Frequency regulation, no-load to full load	0.25%
Engine Electrical System (24 Volt) 60 Hz		Governor: Type:	Electronic Isochronous
Battery charging alternator:		Make:	Perkins
Ground (negative/positive).	Negative	Standard:	ISO 3046-4 class A1
Volts (DC).....	24V	Frequency regulation, steady state	± 0.5%
Ampere rating.....	45A	Frequency	Fixed
Starter motor rated voltage (DC)	24V	Air cleaner type	Dry
Starter motor rated kW:	6.0 Kw		
Battery CCA rating:	1320A		
Battery & qty, AH rating:	2 x 140AH		
Battery Voltage (DC)	24V		
Remote Radiator System		Fuel Consumption 60 Hz	
Exhaust manifold type		Diesel gal/hr (L/hr)	Standby Rating
Connection sizes:		100%	15.0 (56.9)
Water inlet ID hose, mm (in)		75%	11.2 (42.5)
Water outlet ID hose, mm (in)		50%	7.7 (29.3)
Charge air cooling (CAC)	Not Available	25%	4.5 (17.1)
Water inlet ID hose, mm (in)		Diesel gal/hr (L/hr)	Prime Power Rating
Water outlet ID hose, mm (in)		100%	13.6 (51.5)
Static head allowable above engine, ft.H ² O (kPa)		75%	10.2 (38.5)
Maximum CAC restriction H ² O in.		50%	7.0 (26.5)
Contact the HIMOINSA distributor for special cooling options		25%	4.1 (15.5)

Application Data

Cooling		Lubrication	
Radiator Systems	60 Hz	Lubricating System	60 Hz
Ambient temperature, °C (°F)	46 (115)	Type	Full pressure
Engine jacket water capacity L (gal)	12.8 (34)	Oil pan capacity, L, (qt.)	22.7 (24.0)
Radiator system capacity, including engine, L (gal.)	37.2 (9.8)	Recommended lube oil	API CH4/CG-4
Engine jacket water flow, L/min (g/min)	351 (92.7)	Oil pan capacity with filter, L (qt.)	26.4 (27.9)
Heat rejected to cooling water at rated kW, dry exhaust, kW (Btu/min.)	102.5 (5,834)	Oil filter: quantity, type	1, cartridge
Heat rejected to charge cooler at rated kW, dry exhaust, kW (Btu/min.)	28.0 (1,593)	Oil cooler	Oil to water
Water pump type	Centrifugal	Normal oil temperature, °C(°F)	121 (250)
Fan, kWm (HP)	7.0 (9.4)	Ventilation and Air-Flow Requirements	
Max. restriction of cooling air, intake and discharge side of radiator, Pa (in. H ² O)	62.2 (0.25)	Air Requirements	60 Hz
dBA LEVELS SOUND ATTENUATED ENCLOSED	Within (under) 70dBA @ 21 feet	Radiator-cooled cooling air, m ³ /min. (scfm)	480 (16,949)
		Air density kg/m ³ (ibm/ft ³)	1.20 (0.075)
		Heat rejected to exhaust, kW (btu/min)	138 (7,854)
		Heat radiated to surrounding air Engine: kW (Btu)	42 (2,390)
		Combustion air, m ³ /min. (cfm)	19.3 (682)

Dimensions and Weights

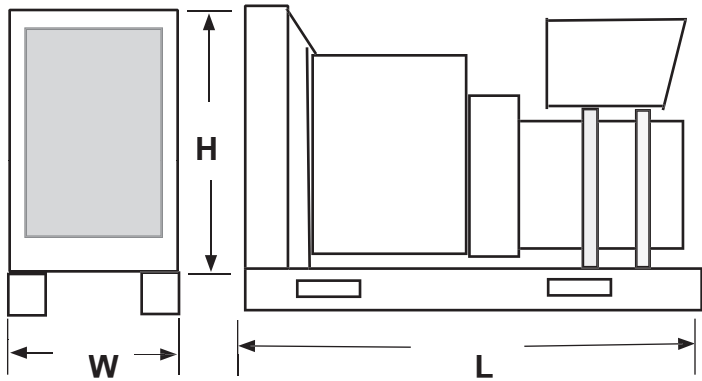
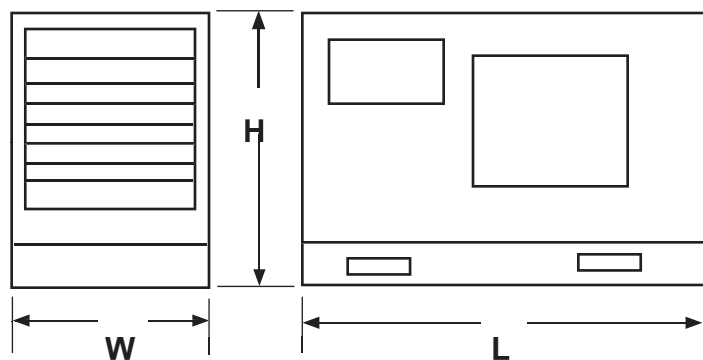
Open Set Model: HP204		Sound Attenuated Set Model: HP204	
Overall size, L x W x H, mm (ins.)	2,800 x 1,100 x 1,770 (110.23 x 43.3 x 69.68)	Overall size, L x W x H, mm (ins.)	3,800 x 1,400 x 2,170 (149.60 x 55.11 x 85.43)
Weight, radiator-mounted model, wet, kg (lb.):	2,059 (4,530)	Weight, radiator-mounted model, wet, kg (lb.):	3,330 (7,326)
Fuel Tank Capacity, L (US gal)	498 (131.74)	Fuel Tank Capacity, L (US gal)	440 (116.4)
			

NOTE: The drawings above are only representative of the overall dimensions. For full detailed installation drawings please consult your local distributor.

RATINGS: Power factor three-phase is 0.8 and single-phase unity. Standby Ratings: Standby ratings assume installation normally served by reliable utility power. The standby rating is available for varying loads for the length of the power outage. No overload is available with the standby rating. Ratings are in accordance with ISO-3046/1 and DIN 6271. Prime Power Ratings: Prime power ratings assume no or unreliable utility power. For varying loads the generator set has unlimited operating hours. A 10% overload capacity is available for any 1 hour in a 12 hour continuous running period. Ratings are in accordance with ISO-3046/1 and DIN 6271. Consult Himoinsa for limited running time and base load ratings. Himoinsa reserves the right to change the design or specifications without notice and without any obligation or liability whatsoever. DERATION GUIDELINES: Altitude: Derate 1.3% per 100 m (328 ft) elevation above 1000 m (3280 ft). Temperature: Derate 1.0% per 10°C (18°F) temperature above 40°C (104°F).